

3501 - MINI LEG PRESS **ASSEMBLY INSTRUCTIONS**



**T.D.S. FITNESS EQUIPMENT
P.O. BOX 4189
ELMIRA, NY 14904, USA
607-733-6789**

3501 - MINI LEG PRESS ASSEMBLY INSTRUCTIONS

DRAWING # 1



3501 - MINI LEG PRESS ASSEMBLY INSTRUCTIONS

DRAWING # 2
(VIEW FROM REAR)

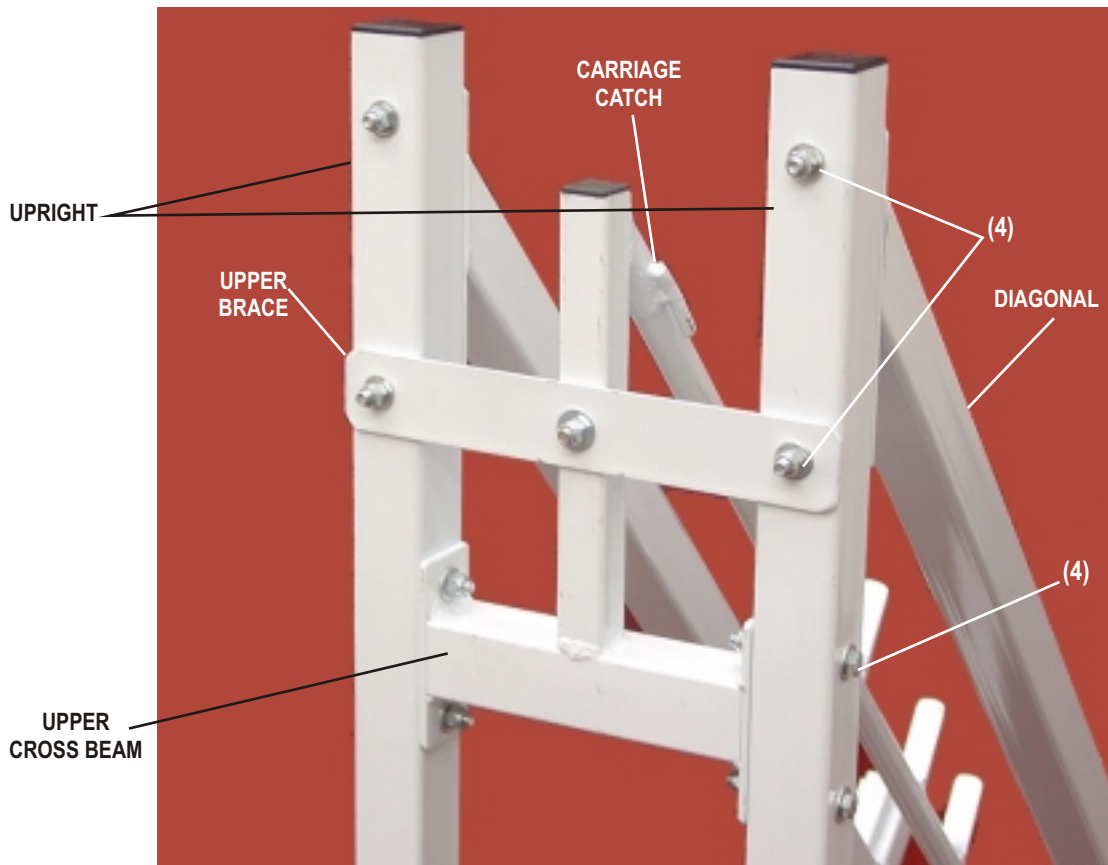

DRAWING # 3

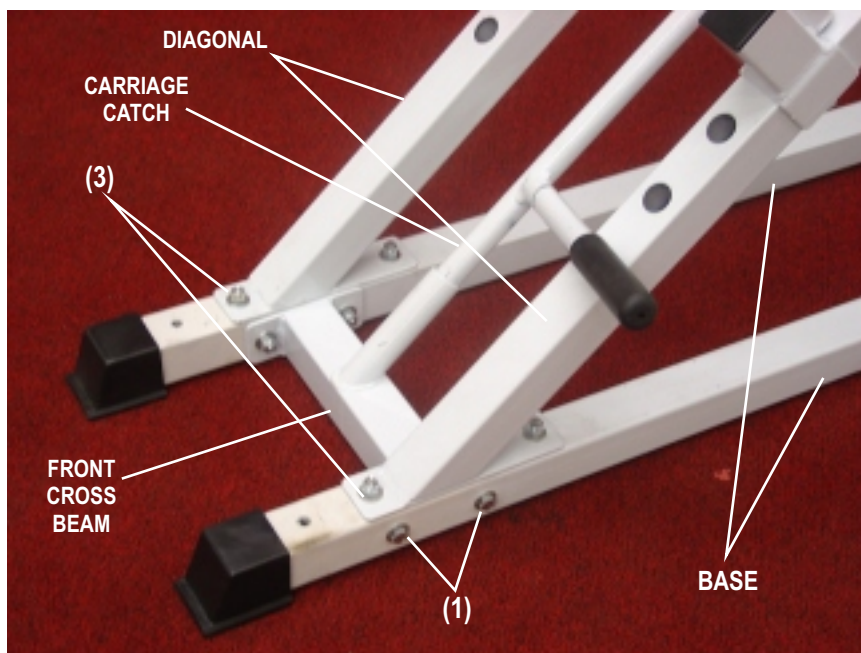

3501 - MINI LEG PRESS ASSEMBLY INSTRUCTIONS

DRAWING # 4

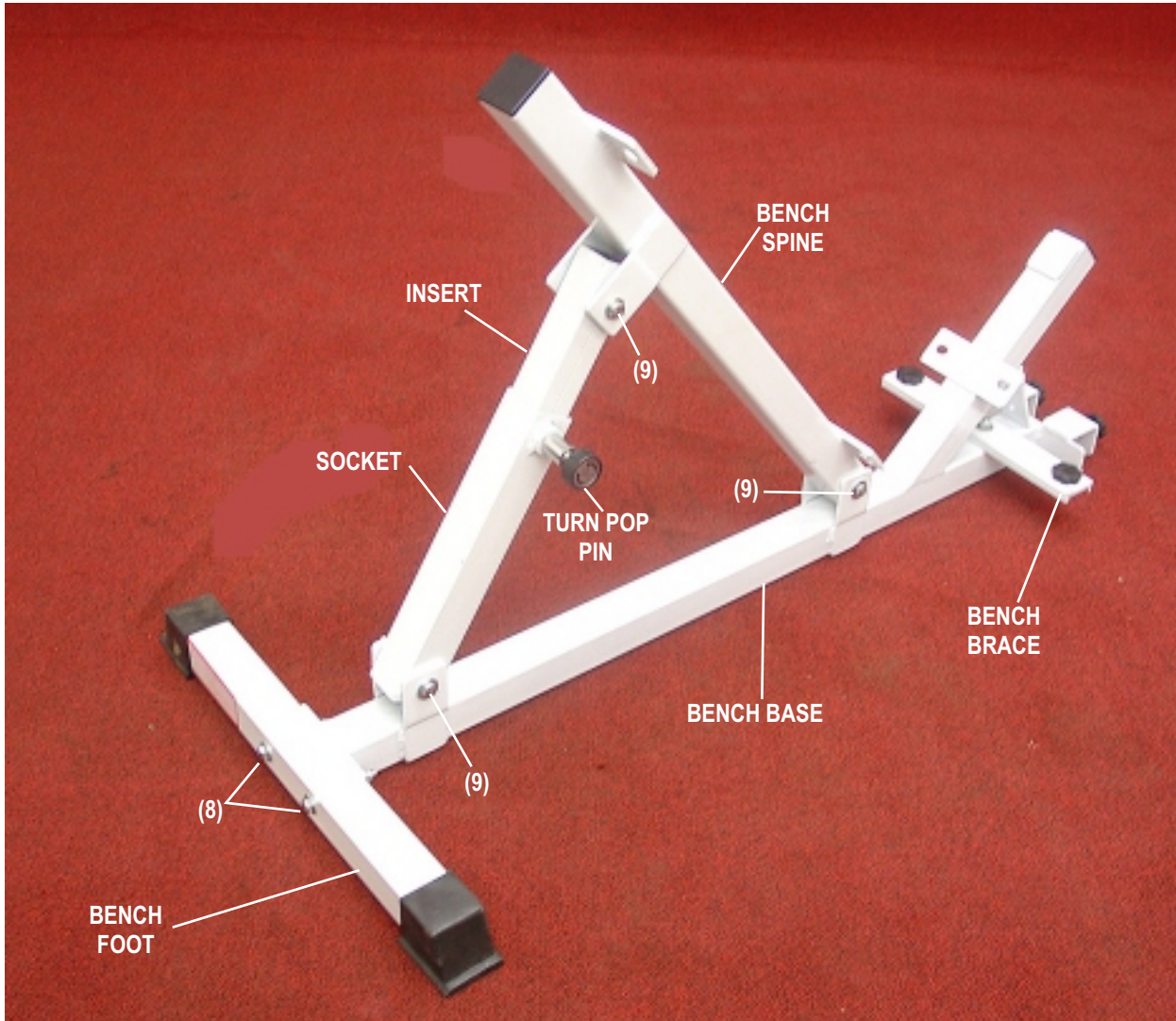

3501 - MINI LEG PRESS ASSEMBLY INSTRUCTIONS

DRAWING # 5

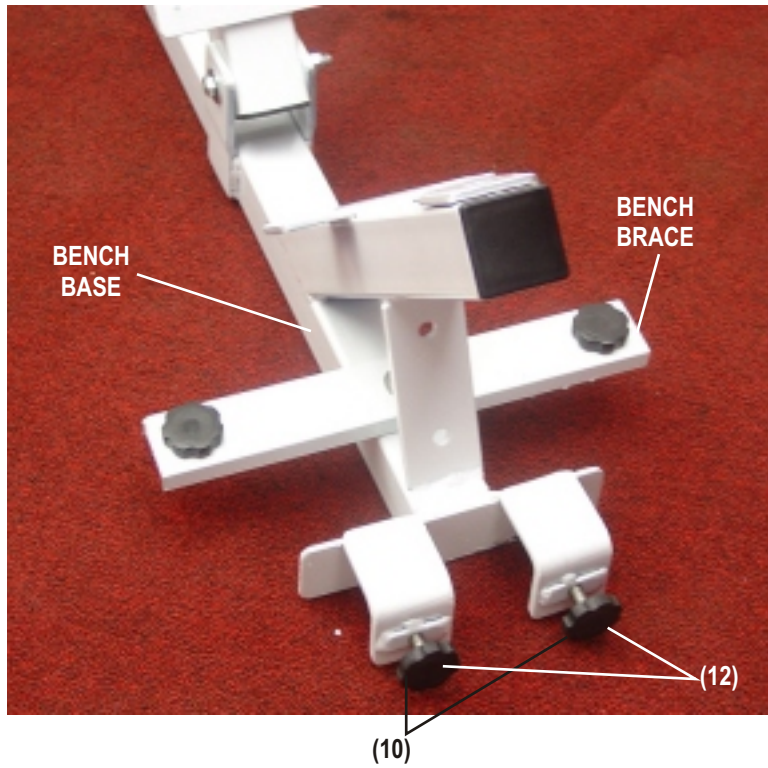

DRAWING # 6

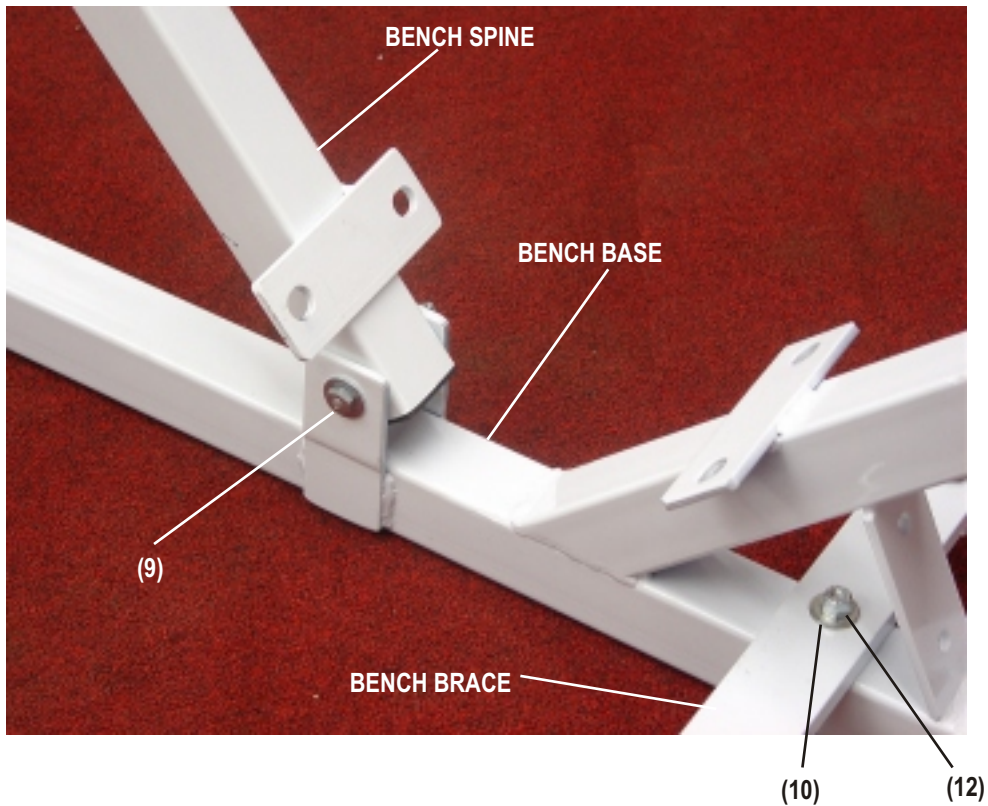

3501 - MINI LEG PRESS ASSEMBLY INSTRUCTIONS

CALF BLOCK
(OPTIONAL)

DRAWING # 12

FOOT PLATE

PLATES SHOWN
FOR INFORMATION
(NOT INCLUDED)

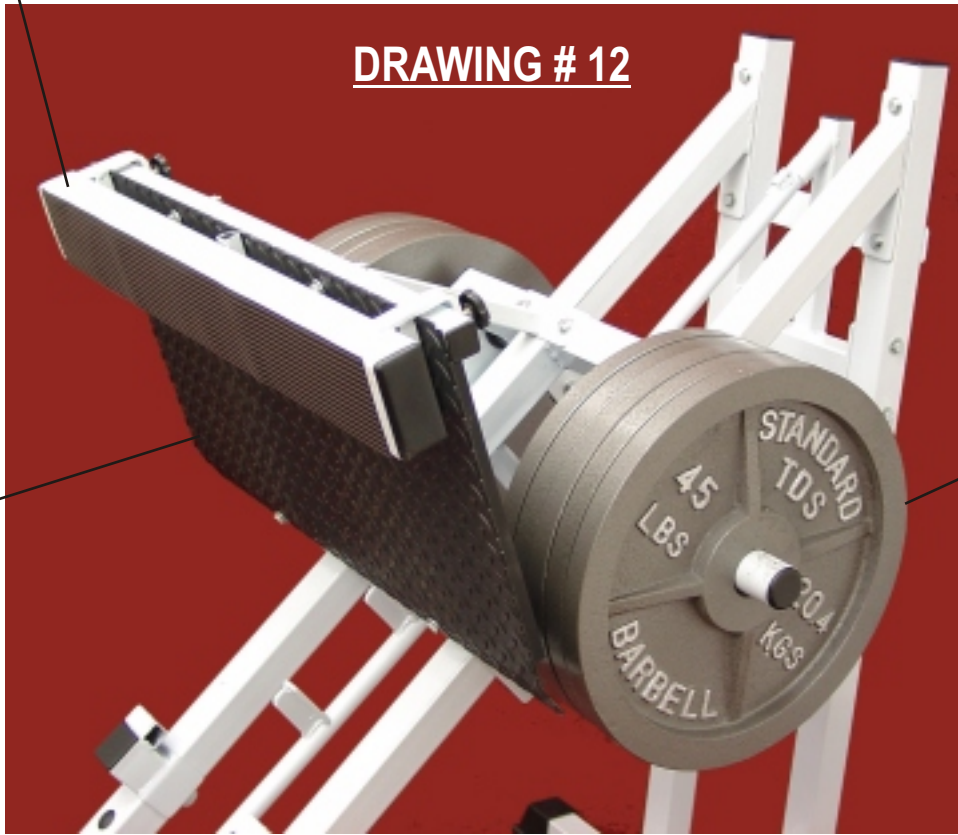

DRAWING # 7

ROLLERS (8)

CARRIAGE

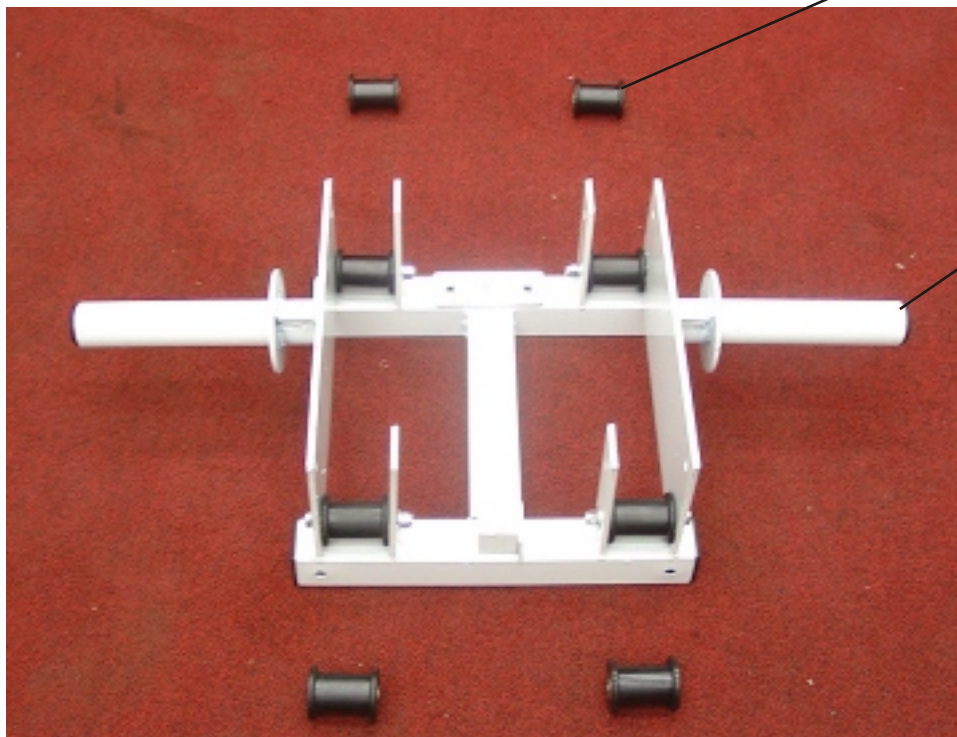

3501 - MINI LEG PRESS ASSEMBLY INSTRUCTIONS

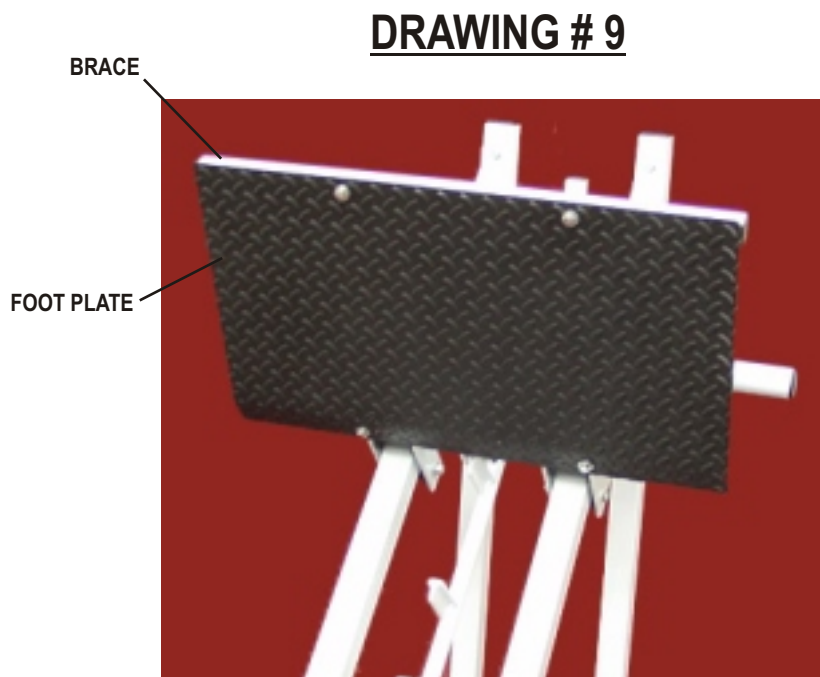
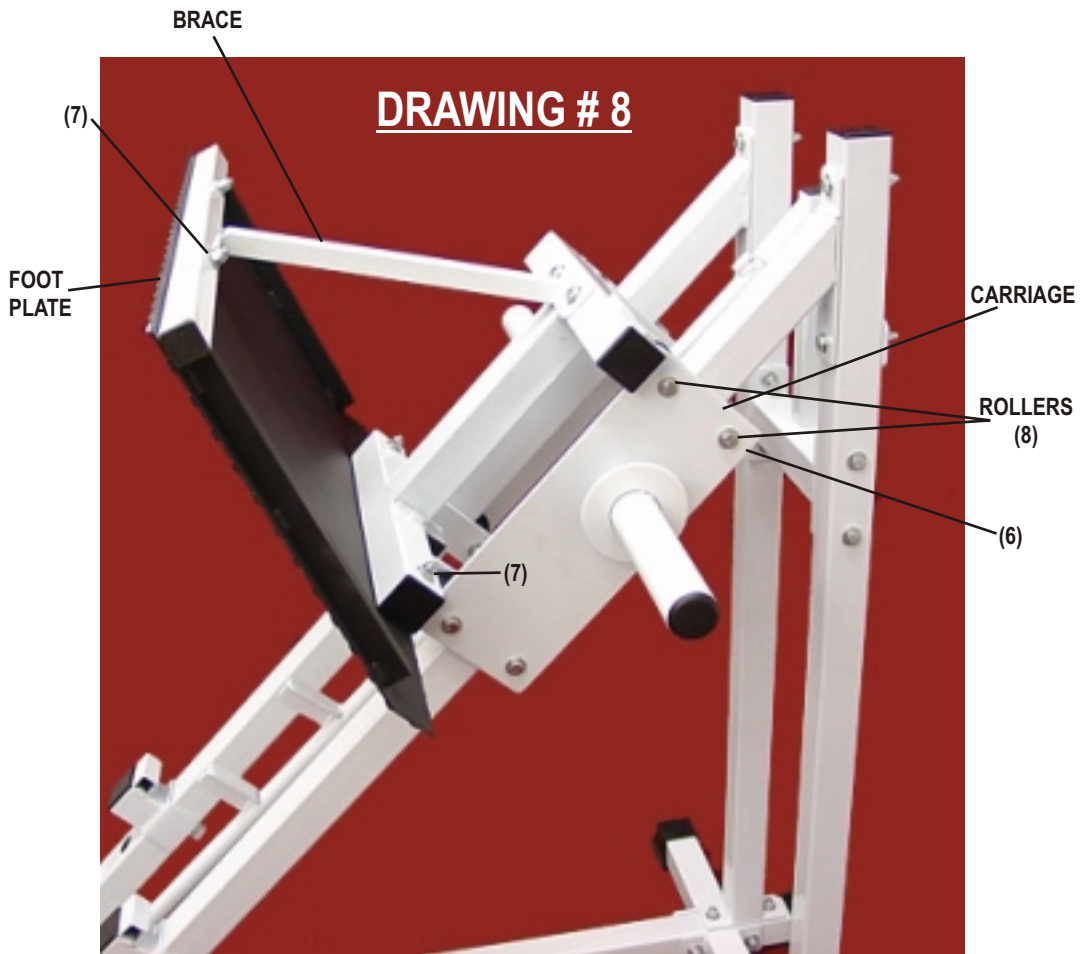

3501 - MINI LEG PRESS ASSEMBLY INSTRUCTIONS

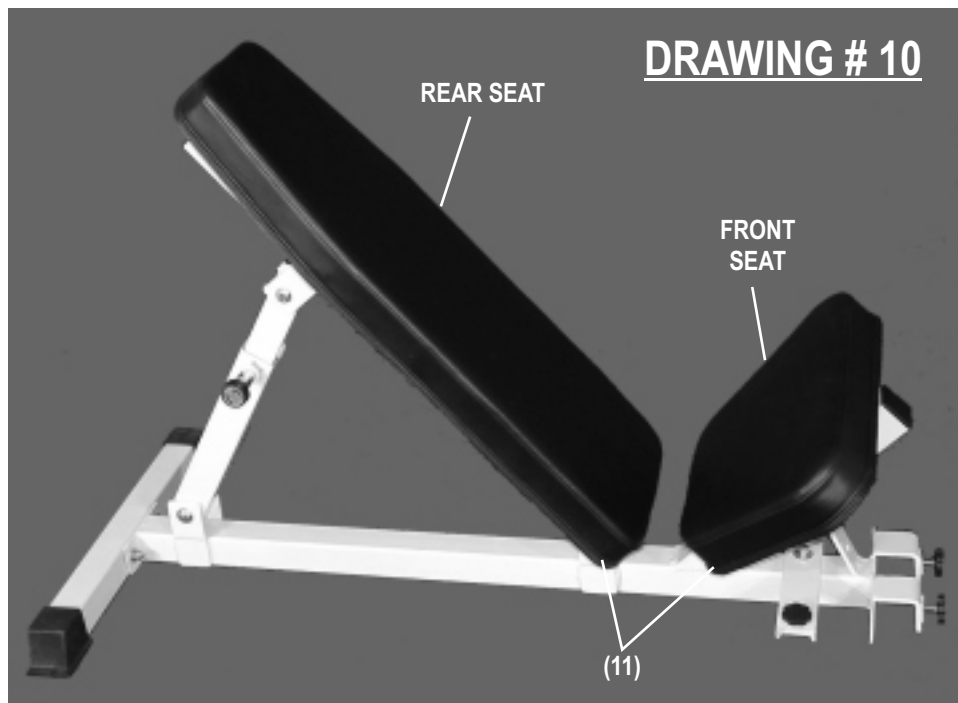

DRAWING # 11

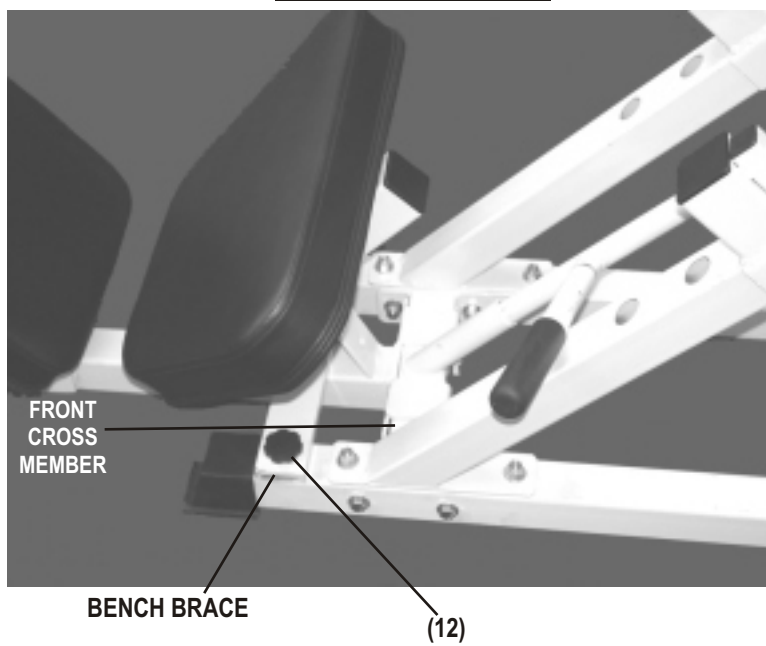

3105 W - MINI LEG PRESS
PACKING LIST - BOX 1 OF 3

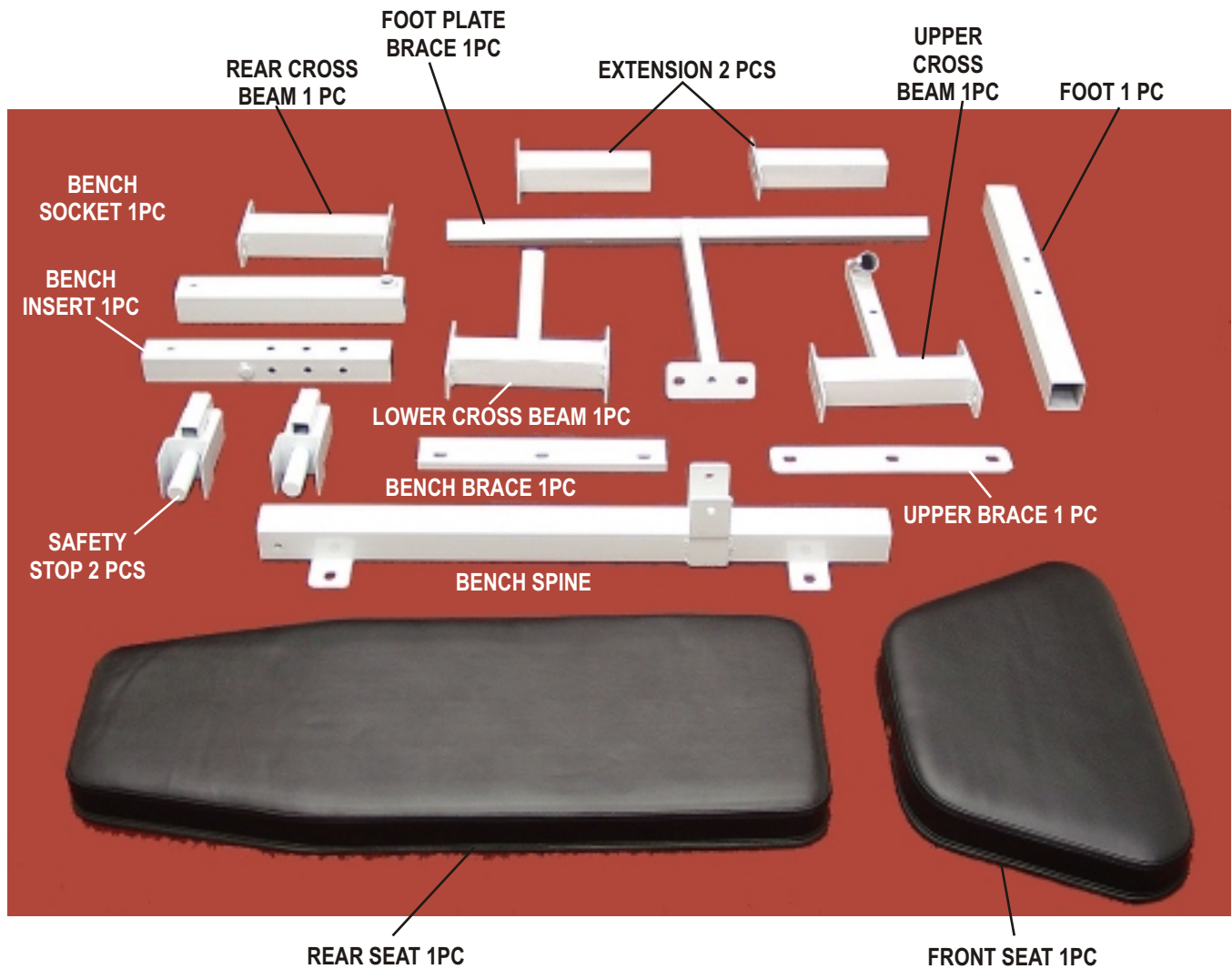

LITERATURE 1 PKG

HARDWARE 1 PKG

FLANGED ROLLERS
8 PCS

T.D.S. FITNESS EQUIPMENT
P.O. BOX 4189
ELMIRA, NY 14904, USA
607-733-6789

3105 W - MINI LEG PRESS
PACKING LIST - BOX 2 OF 3

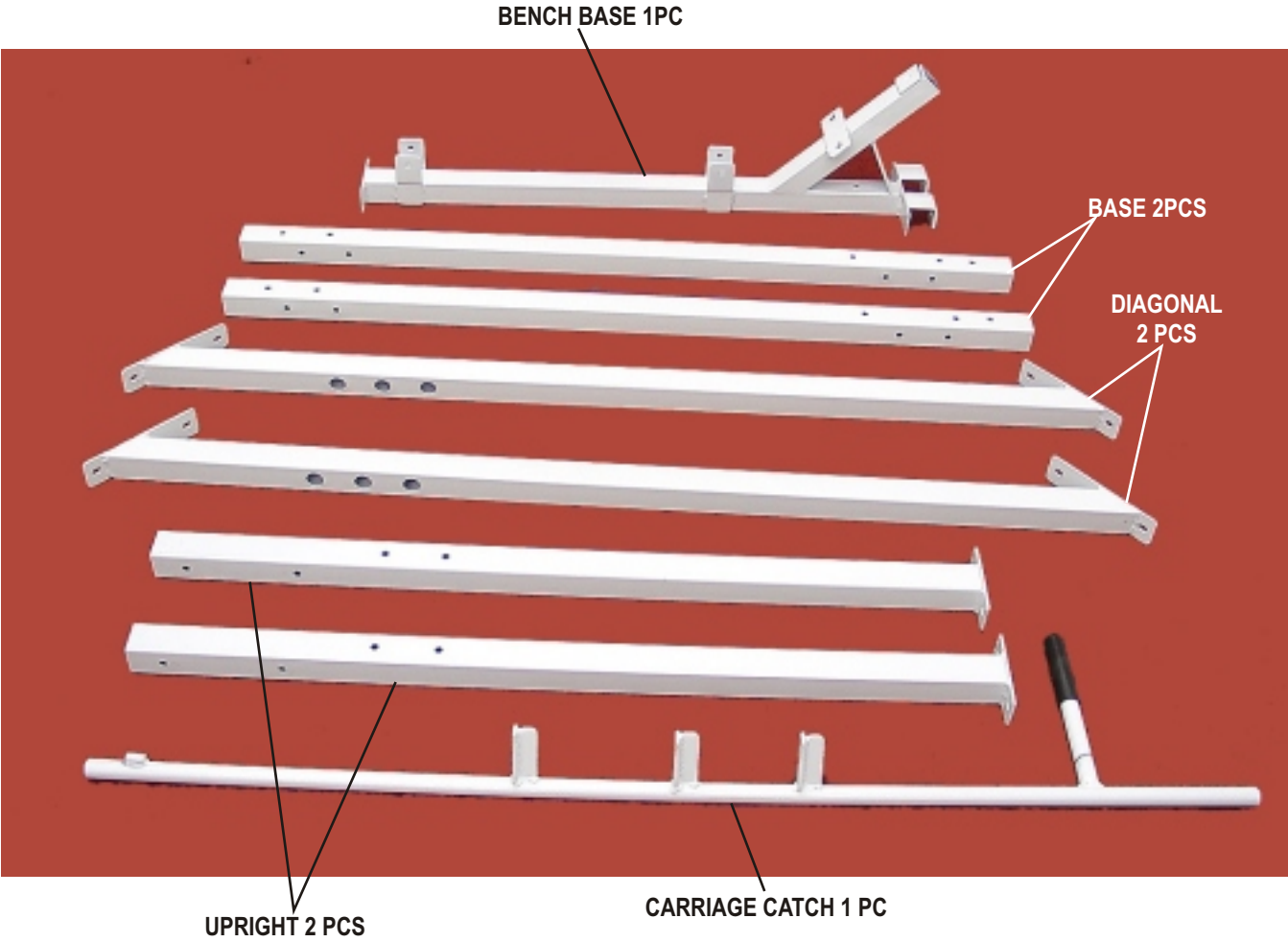

T.D.S. FITNESS EQUIPMENT
P.O. BOX 4189
ELMIRA, NY 14904, USA
607-733-6789

3105 W - MINI LEG PRESS
PACKING LIST - BOX 3 OF 3

CARRIAGE 1PC



FOOT PLATE 1PC

T.D.S. FITNESS EQUIPMENT
P.O. BOX 4189
ELMIRA, NY 14904, USA
607-733-6789